



COMMERCIAL KITCHEN SOLUTIONS

Sinks

Quality
Delivered as Promised

SINGLE SINK UNIT

We understand the demanding environment of a commercial food preparation area, may it be a commercial kitchen , a food processing industry or a laboratory.

Star Opus range of sink units have been developed focusing on the maximum hygiene coupled with strength and durability , helping you to wash cookware , cutlery , and more with ease.



Single Sink

PRODUCT FEATURES

- Sunken Top
- Top constructed out of 1.2.mm thick SS 304 Sheets
- Available in depths of 450/600/700 & 900 mm
- Angular Frame structure constructed out of 25mm x 25mm x 3mm thick Stainless Steel Angles
- Legs constructed out of 38mm square/round Stainless Steel Pipes
- Cross Bracing constructed out of 25mm square/round Stainless Steel Pipes
- Shelves constructed out of 1mm thick Stainless Steel sheet
- Legs resting on adjustable Nylon Bullet Feets
- All TIG welded for exposed areas & polished to No.4 Finish

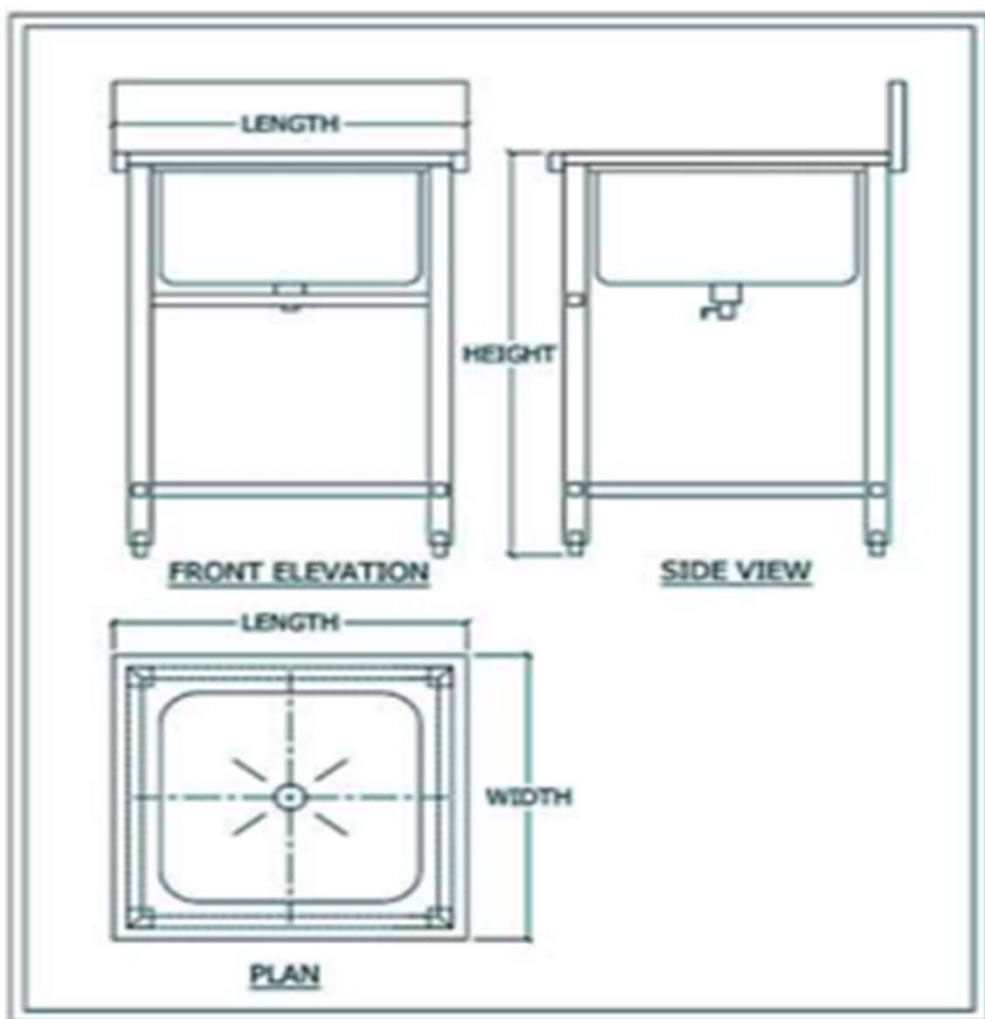

OPTIONAL ACCESORIES

- Back /One /Two side Cladding above shelf constructed out of 1mm thick SS Sheet
- Front Doors
- Strainer for Sink Unit
- Faucets
- Foot operated Valve with faucet
- Sensor operated Valve with faucet
- Automatic Soap Dispenser
- Hand Dryer
- Strong & Durable Castor Wheels
- Laser operated Drain with overflow pass
- Ask us for Customisation of your Requirement

DOUBLE SINK UNIT

We understand the demanding environment of a commercial food preparation area, may it be a commercial kitchen, a food processing industry or a laboratory. Star Opus range of sink units have been developed on the maximum hygiene coupled with strength and durability, helping you to wash cookware, cutlery, crockery and more with ease.



Double Sink

PRODUCT FEATURES

- 1) Sunken Top
- 2) Top constructed out of 1.2mm thick SS 304 Sheets
- 3) Available in depths of 450/600/700 & 900 mm
- 4) Angular Frame structure constructed out of 25mm x 25mm x 3mm thick Stainless Steel Angles
- 5) Legs constructed out of 38mm square/round Stainless Steel Pipes
- 6) Cross Bracing constructed out of 25mm square/round Stainless Steel Pipes
- 7) Shelves constructed out of 1mm thick Stainless Steel sheet
- 8) Legs resting on adjustable Nylon Bullet Feet
- 9) All TIG welded for exposed areas & polished to No.4 Finish

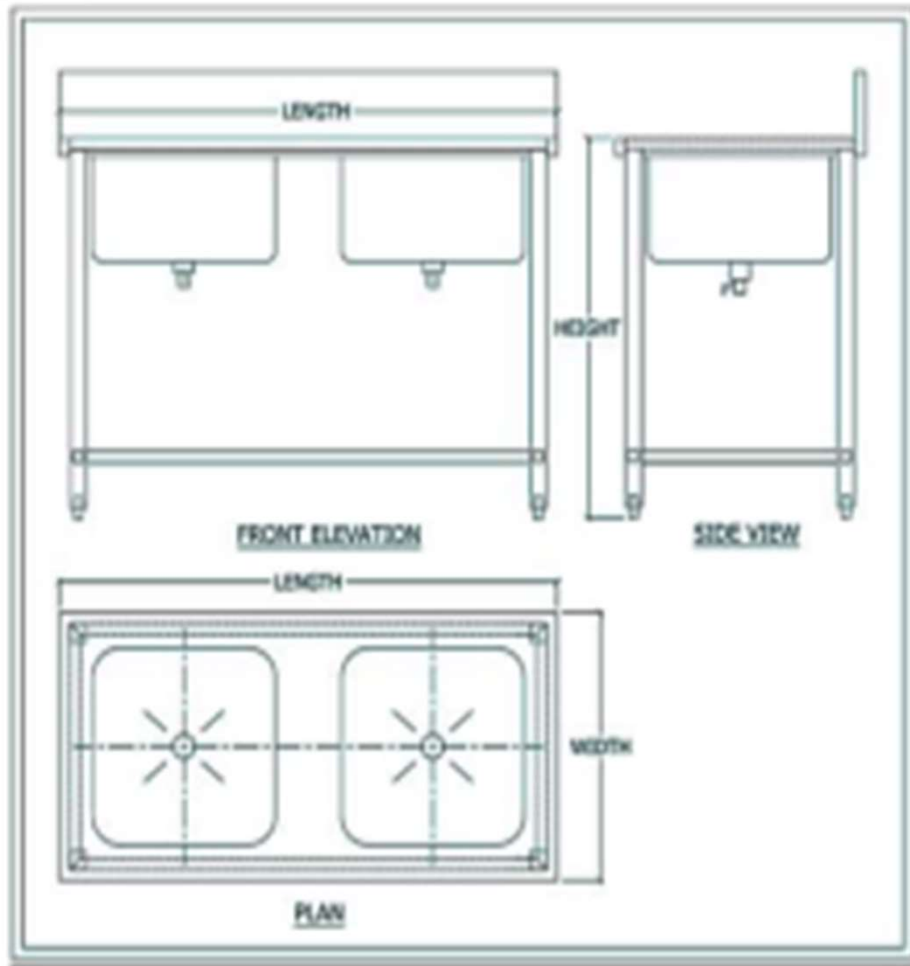

OPTIONAL ACCESORIES

- Back /One /Two side Cladding above shelf constructed out of 1mm thick SS Sheet
- Front Doors
- Strainer for Sink Unit
- Faucets
- Foot operated Valve with faucet
- Sensor operated Valve with faucet
- Automatic Soap Dispenser
- Hand Dryer
- Strong & Durable Castor Wheels
- Laser operated Drain with overflow pass
- Ask us for Customisation of your Requirement



info@opusinnovations.in



Mumbai - (+91) 8452840506 Goa - (+91) 9860555648
Kolkata - (+91) 9830300238 Raipur - (+91) 9425208979



Unit Q1, Khan Compound, Vasai Highway,
Pelhar, Vasai, Palghar, Mumbai (M.H.) - 401202