



**COMMERCIAL
KITCHEN SOLUTIONS**

Cooking Ranges

Quality
Delivered as Promised

SINGLE BURNER INDIAN COOKING RANGE

A well designed Range compliments the Artisan food dished by the Chef.

STAR OPUS range of Single Burner Indian Cooking Range has been designed & manufactured after extensive discussion with Chefs. Durability, Aesthetic looks & Hygienic factors have been the focus while designing the product for your Professional Kitchen.



Single Burner Indian Range

PRODUCT FEATURES

- Single Burner Indian Range available in 600/750 & 900 mm depth
- 304 in Standard model & 202 in Economical model, 1.2mm thick Stainless Steel Top
- Cast Iron durable Pan rest
- Quality tested Burners.
- Pilot Lamp for Each Burner
- Bigger durable knobs for ease of operation, colour coded knobs, Red for Main Burner & Black for Pilot Lamps
- Angular Frame structure constructed out of 25mm x 25mm x 3mm thick Stainless Steel Angles
- Cladding with units constructed out of 1mm thick Stainless Steel Sheet
- Full length Drip Tray for collecting crumbs of food & spillage constructed out of 1mm Stainless Steel Sheet
- Legs constructed out of 38mm square/round Stainless Steel Pipes
- Cross Bracing constructed out of 25mm square/round Stainless Steel Pipes
- Shelves constructed out of 1mm thick Stainless Steel sheet
- Legs resting on adjustable Nylon Bullet to accommodate uneven flooring
- All TIG welded for exposed areas & polished to No.4 Finish

OPTIONAL ACCESORIES

- Back /One /Two side Cladding above shelf constructed out of 1mm thick Stainless Steel Sheet.
- Strong & Durable Castor Wheels.
- Ask us for Customization of your Requirement.

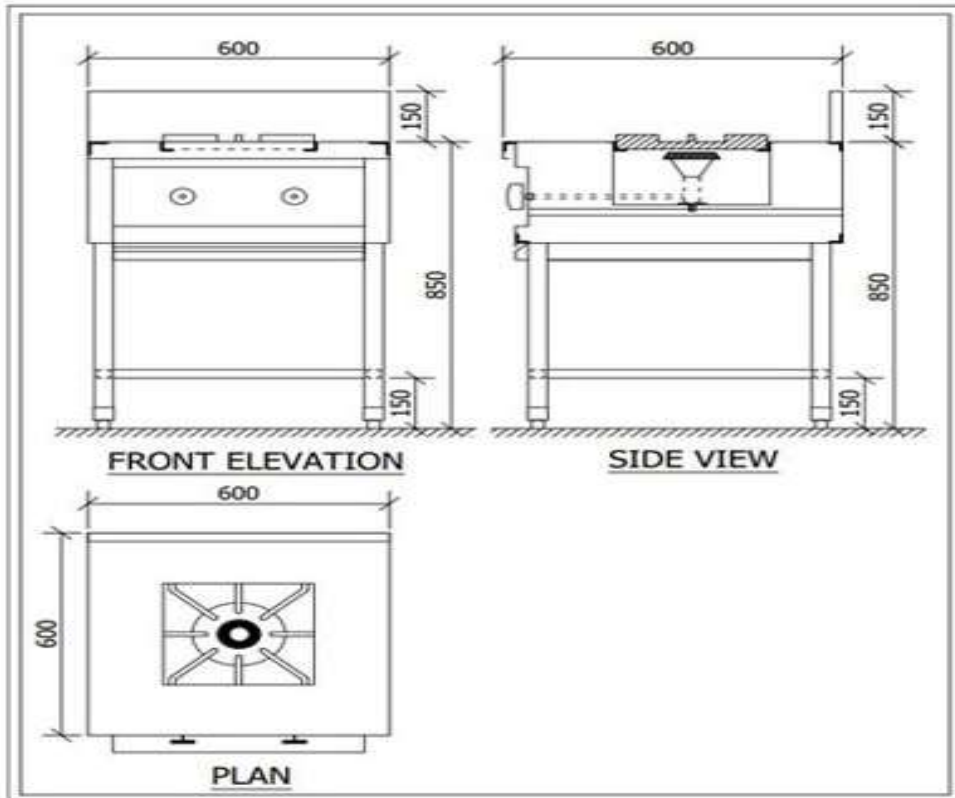
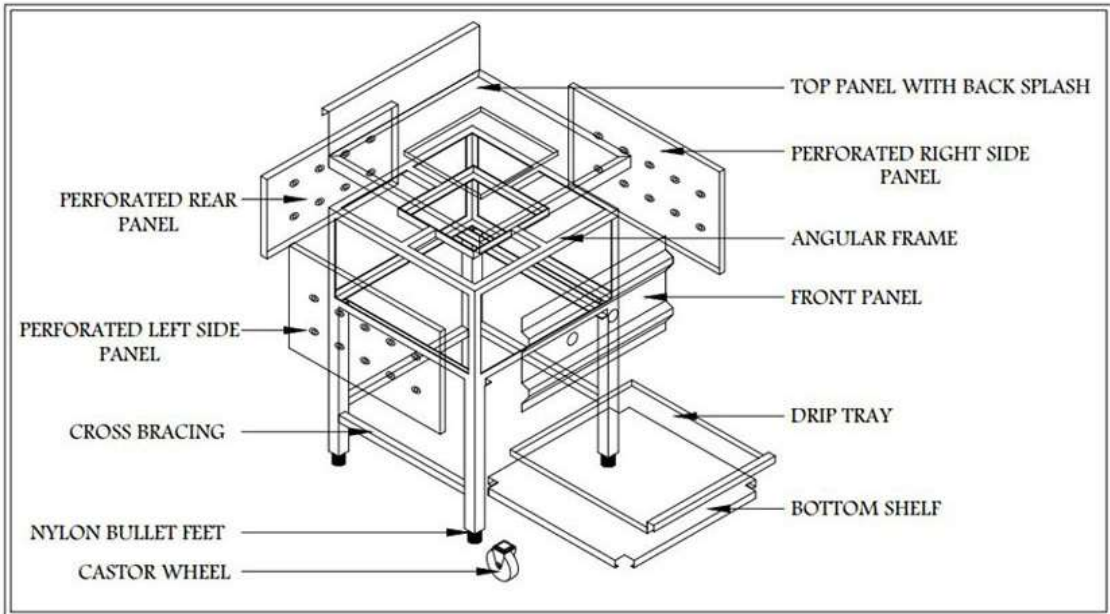

SINGLE BURNER CHINESE RANGE

Stir frying a mouth watering oriental dish STAR OPUS Chinese Range compliments the Chef's effort providing a durable Chinese Range. Did you know, due to the extra heat generated by the high pressure Torch Burner the top of the Range is overheated & tends to distort over a period of time?

STAR OPUS Chinese Range eliminates this problem by providing a water bath on the front of the Range which cools of the Top & prevents distortion, also the food crumbs drain out along with the water keeping the top clean.



Single Burner Chinese Range

PRODUCT FEATURES

- Chinese Range available in 750/ 900 mm depth
- Water bath on the Front & Rear drain with perforated cover
- High Splash Back with provision of fitting a water spout
- 304 in Standard model & 202 in Economical model, 1.2mm thick Stainless Steel Top
- Cast Iron durable Pan rest
- Quality tested Burners
- Pilot Lamp for Each Burner
- Bigger durable knobs for ease of operation, colour coded knobs, Red for Main Burner & Black for Pilot Lamp
- Angular Frame structure constructed out of 25mm x 25mm x 3mm thick Stainless Steel Angles
- Cladding with units constructed out of 1mm thick Stainless Steel Sheet
- Full length Drip Tray for collecting crumbs of food & spillage constructed out of 1mm Stainless Steel Sheet
- Legs constructed out of 38mm square/round Stainless Steel Pipes
- Cross Bracing constructed out of 25mm square/round Stainless Steel Pipes
- Shelves constructed out of 1mm thick Stainless Steel sheet
- Legs resting on adjustable Nylon Bullet Feet to accommodate uneven flooring
- 1All TIG welded for exposed areas & polished to No.4 Finish

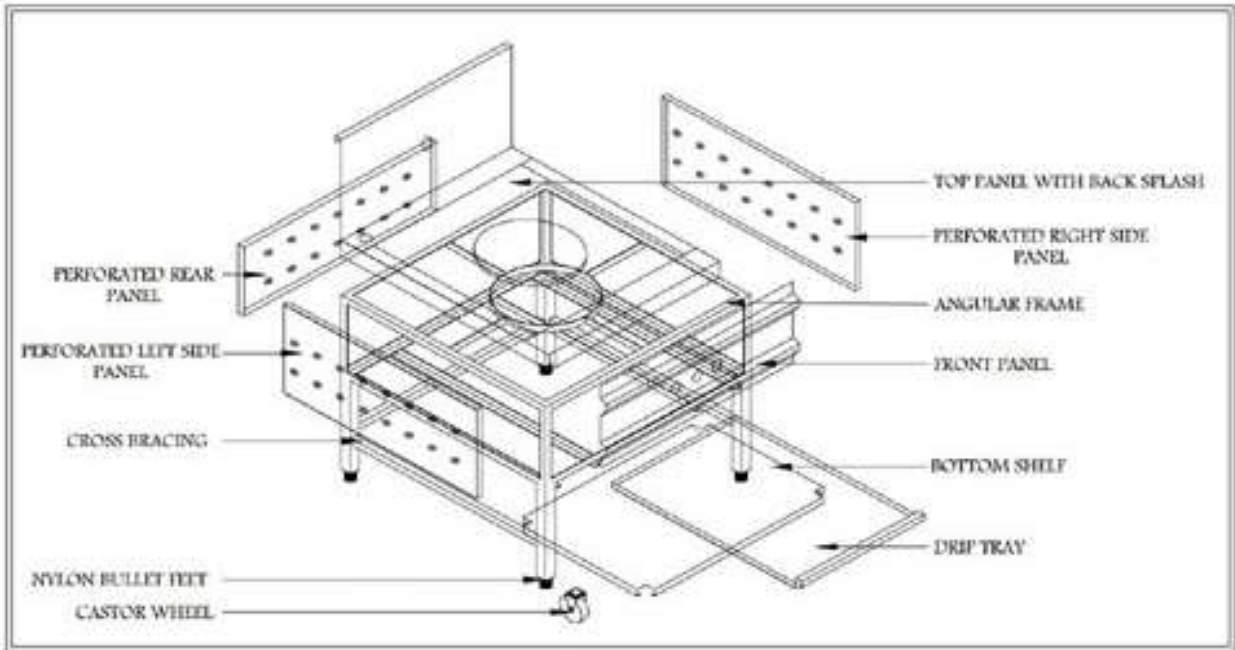

OPTIONAL ACCESORIES

- Baffle Rack on the Sides or on Back Splash
- Water Spout
- Back /One /Two side Cladding above shelf constructed out of 1mm thick Stainless Steel Sheet
- Strong & Durable Castor Wheels
- Ask us for Customization of your Requirement

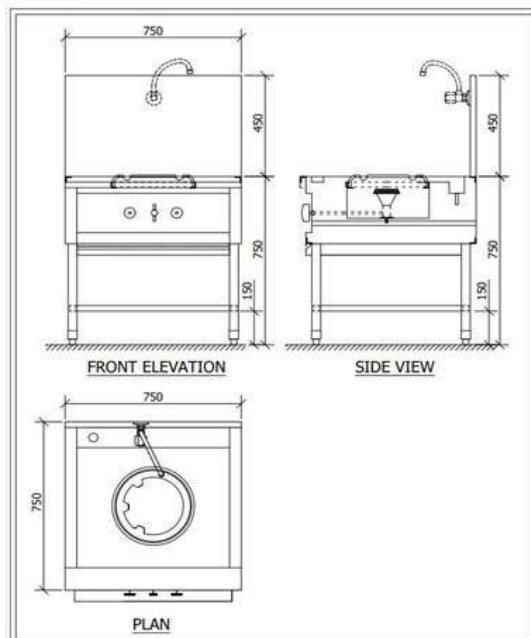

TWO BURNER CHINESE RANGE WITH ONE STOCK POT

Stir frying a mouth watering oriental dish STAR OPUS Chinese Range compliments the Chef's effort providing a durable Chinese Range. Did you know, due to the extra heat generated by the high pressure Torch Burner the top of the Range is overheated & tends to distort over a period of time?

STAR OPUS Chinese Range eliminates this problem by providing a water bath on the front of the Range which cools of the Top & prevents distortion, also the food crumbs drain out along with the water keeping the top clean.



Two Burner Chinese Range

PRODUCT FEATURES

- Chinese Range available in 750/ 900 mm depth
- Water bath on the Front & Rear drain with perforated cover
- High Splash Back with provision of fitting a water spout
- 304 in Standard model & 202 in Economical model, 1.2mm thick Stainless Steel Top
- Cast Iron durable Pan rest
- Quality tested Burners
- Pilot Lamp for Each Burner
- Bigger durable knobs for ease of operation, colour coded knobs, Red for Main Burner & Black for Pilot Lamps
- Angular Frame structure constructed out of 25mm x 25mm x 3mm thick Stainless Steel Angles
- Cladding with units constructed out of 1mm thick Stainless Steel Sheet
- Full length Drip Tray for collecting crumbs of food & spillage constructed out of 1mm Stainless Steel Sheet
- Legs constructed out of 38mm square/round Stainless Steel Pipes
- Cross Bracing constructed out of 25mm square/round Stainless Steel Pipes

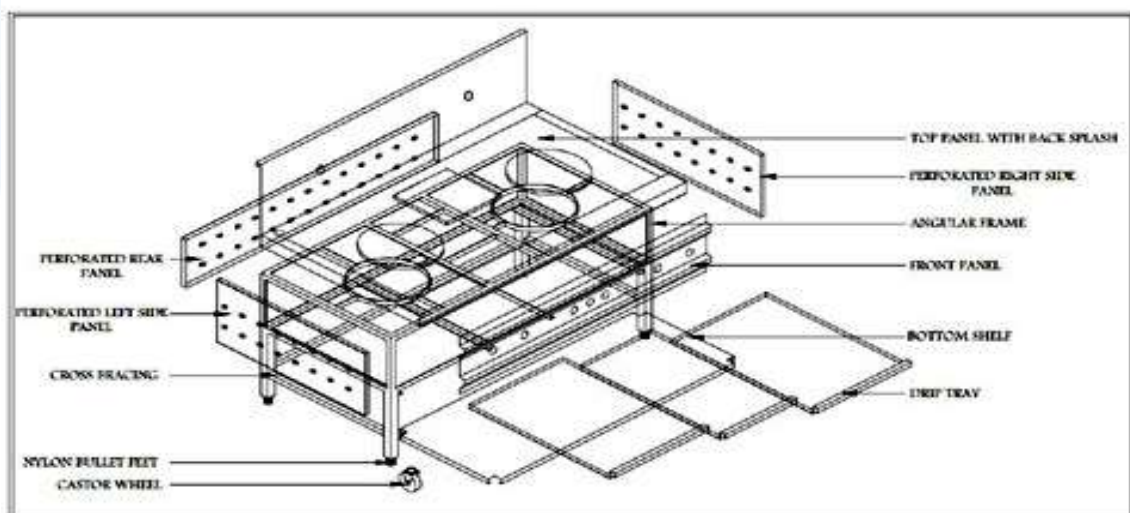

- Shelves constructed out of 1 mm thick Stainless Steel sheet
- Legs resting on adjustable Nylon Bullet Feet to accommodate uneven flooring
- All TIG welded for exposed areas & polished to No.4 Finish.
- Stainless Steel Sheet
- Full length Drip Tray for collecting crumbs of food & spillage constructed out of 1 mm Stainless Steel Sheet
- Legs constructed out of 38mm square/round Stainless Steel Pipes
- Cross Bracing constructed out of 25mm square/round Stainless Steel Pipes
- Shelves constructed out of 1 mm thick Stainless Steel sheet
- Legs resting on adjustable Nylon Bullet to accommodate uneven flooring
- All TIG welded for exposed areas & polished to No.4 Finish

OPTIONAL ACCESORIES

- Baffle Rack on the Sides or on Back Splash.
- Water Spout
- Back /One /Two side Cladding above shelf constructed out of 1 mm thick Stainless Steel Sheet
- Strong & Durable Castor Wheels
- Ask us for Customizations of your Requirement

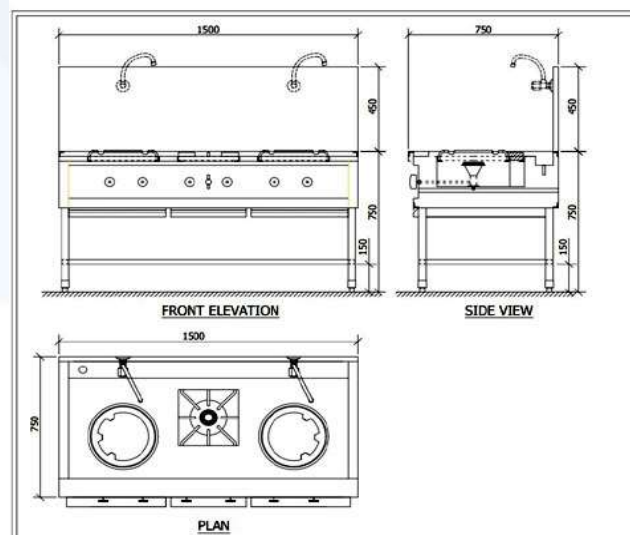

TWO BURNER INDIAN COOKING RANGE

A well designed Range compliments the Artisan food dished by the Chef. STAR OPUS range of Two Burner Indian Cooking Range has been designed & manufactured after extensive discussion with Chefs. Durability, Aesthetic looks & Hygienic factors have been the focus while designing the product for your Professional Kitchen.



Two Burner Indian Range

PRODUCT FEATURES

- Two Burner Indian Range available in 600/750 & 900 mm depth
- 304 in Standard model & 202 in Economical model, 1.2mm thick Stainless Steel Top
- Cast Iron durable Pan rest
- Quality tested Burners
- Pilot Lamp for Each Burner
- Bigger durable knobs for ease of operation, colour coded knobs, Red for Main Burner & Black for Pilot Lamps
- Angular Frame structure constructed out of 25mm x 25mm x 3mm thick Stainless Steel Angles
- Cladding with units constructed out of 1mm thick Stainless Steel Sheet
- Full length Drip Tray for collecting crumbs of food & spillage constructed out of 1mm Stainless Steel Sheet
- Legs constructed out of 38mm square/round Stainless Steel Pipes
- Cross Bracing constructed out of 25mm square/round Stainless Steel Pipes
- Shelves constructed out of 1mm thick Stainless Steel sheet
- Legs resting on adjustable Nylon Bullet Feet to accommodate uneven flooring
- All TIG welded for exposed areas & polished to No.4 Finish

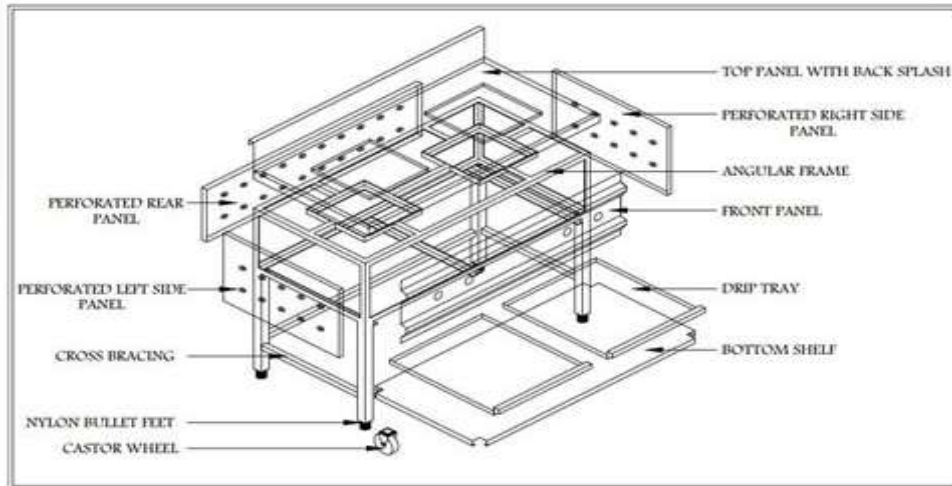

OPTIONAL ACCESSORIES

- Back /One /Two side Cladding above shelf constructed out of 1mm thick Stainless Steel Sheet
- Strong & Durable Castor Wheels
- Ask us for Customization of your Requirement

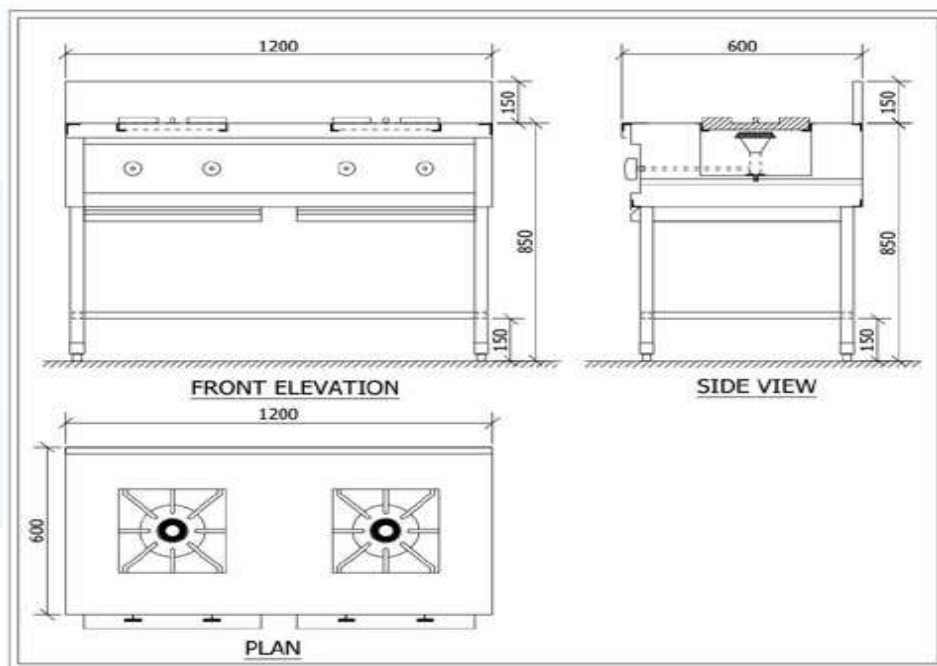

THREE BURNER INDIAN COOKING RANGE

A well designed Range compliments the Artisan food dished by the Chef.

STAR OPUS range of Three Burner Indian Cooking Range has been designed & manufactured after extensive discussion with Chefs. Durability, Aesthetic looks & Hygienic factors have been the focus while designing the product for your Professional Kitchen.



Three Burner Indian Range

PRODUCT FEATURES

- Three Burner Indian Range available in 600/750 & 900 mm depth
- 304 in Standard model & 202 in Economical model, 1.2mm thick Stainless Steel Top
- Cast Iron durable Pan rest
- Quality tested Burners
- Pilot Lamp for Each Burner
- Bigger durable knobs for ease of operation, colour coded knobs, Red for Main Burner & Black for Pilot Lamps
- Angular Frame structure constructed out of 25mm x 25mm x 3mm thick Stainless Steel Angles
- Cladding with units constructed out of 1mm thick Stainless Steel Sheet
- Full length Drip Tray for collecting crumbs of food & spillage constructed out of 1mm Stainless Steel Sheet
- Legs constructed out of 38mm square/round Stainless Steel Pipes
- Cross Bracing constructed out of 25mm square/round Stainless Steel Pipes
- Shelves constructed out of 1mm thick Stainless Steel sheet
- Legs resting on adjustable Nylon Bullet Feet to accommodate uneven flooring
- All TIG welded for exposed areas & polished to No.4 Finish

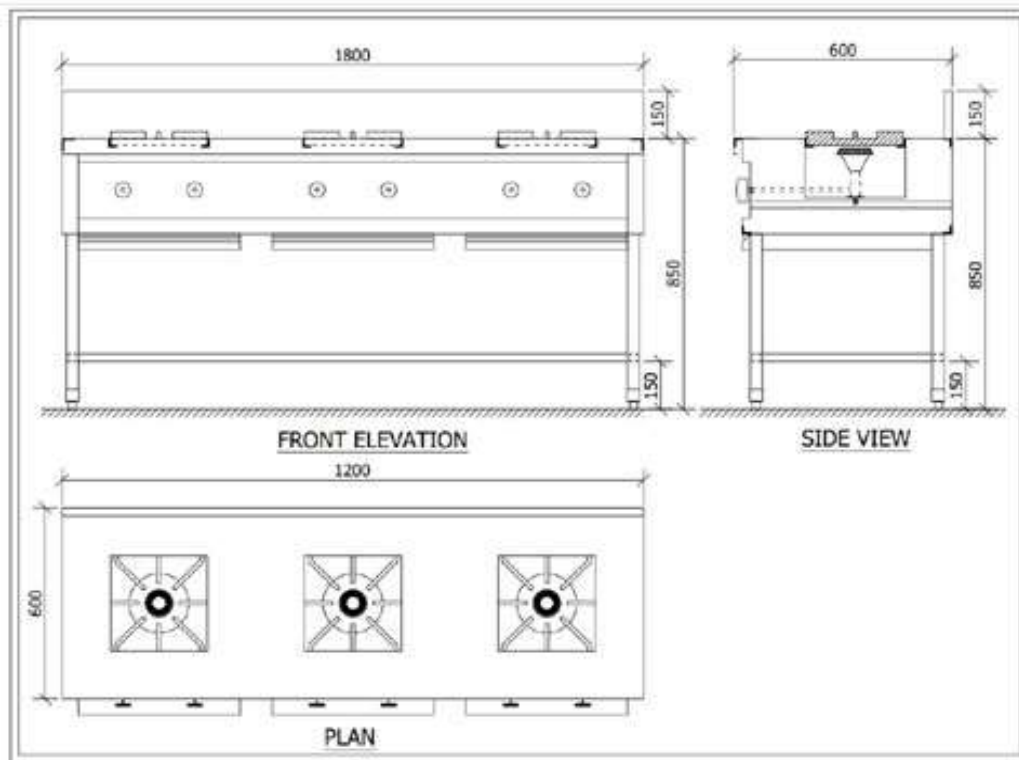

OPTIONAL ACCESORIES

- Back /One /Two side Cladding above shelf constructed out of 1mm thick Stainless Steel Sheet
- Strong & Durable Castor Wheels
- Ask us for Customization of your Requirement

FOUR BURNER CONTINENTAL RANGE

Stewing a fine Continental Dish? STAR OPUS Four Burner Continental Range with gentle flame from Sun flame Burners work with the Chef in creating a gastronomic experience for your Guest.

The Four Burner Range has been designed & manufactured after extensive discussion with Chefs. Style, elegance & a gentle touch with the highest level of Hygiene has been the focus in designing the product for your Professional Kitchen.



Four Burner Continental Range

PRODUCT FEATURES

- Four Burner Continental Range available in 750/ 900 mm depth
- 304 in Standard model & 202 in Economical model, 1.2mm thick Stainless Steel Top
- Cast Iron durable Pan rest
- Quality tested Burners
- Pilot Lamp for Two Burner
- Bigger durable knobs for ease of operation, colour coded knobs, Red for Main Burner & Black for Pilot Lamps
- Angular Frame structure constructed out of 25mm x 25mm x 3mm thick Stainless Steel Angles
- Cladding with units constructed out of 1mm thick Stainless Steel Sheet
- Full length Drip Tray for collecting crumbs of food & spillage constructed out of 1mm Stainless Steel Sheet
- Legs constructed out of 38mm square/round Stainless Steel Pipes
- Cross Bracing constructed out of 25mm square/round Stainless Steel Pipes
- Shelves constructed out of 1mm thick Stainless Steel sheet
- Legs resting on adjustable Nylon Bullet Feet to accommodate uneven flooring
- All TIG welded for exposed areas & polished to No.4 Finish

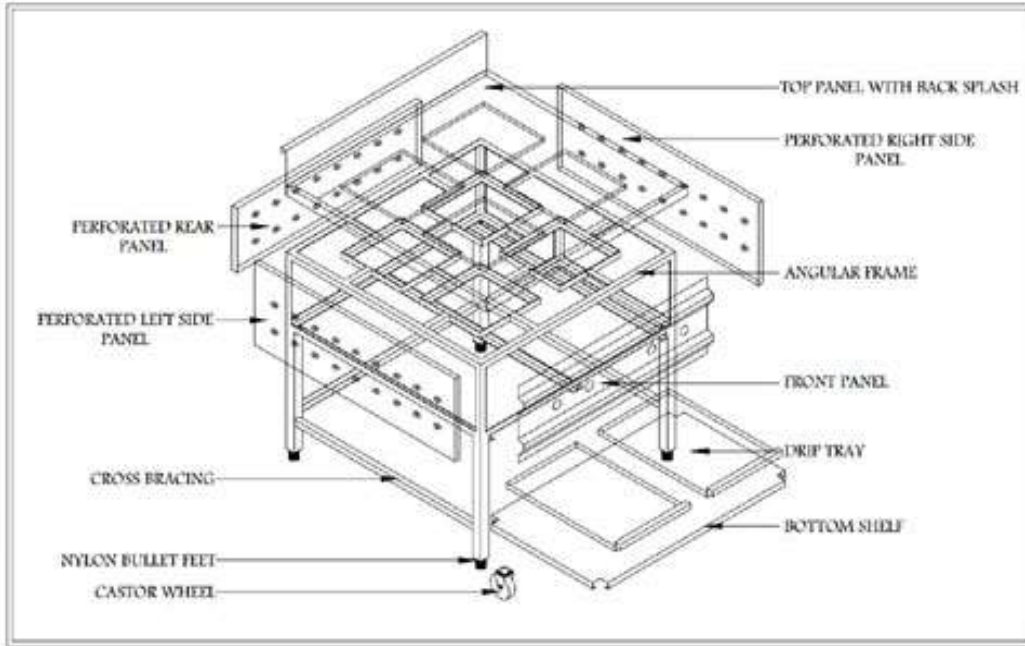

OPTIONAL ACCESSORIES

- Griddle plate Half Ribbed/ Plain
- Back /One /Two side Cladding above shelf constructed out of 1mm thick Stainless Steel Sheet
- Strong & Durable Castor Wheels
- Ask us for Customization of your Requirement

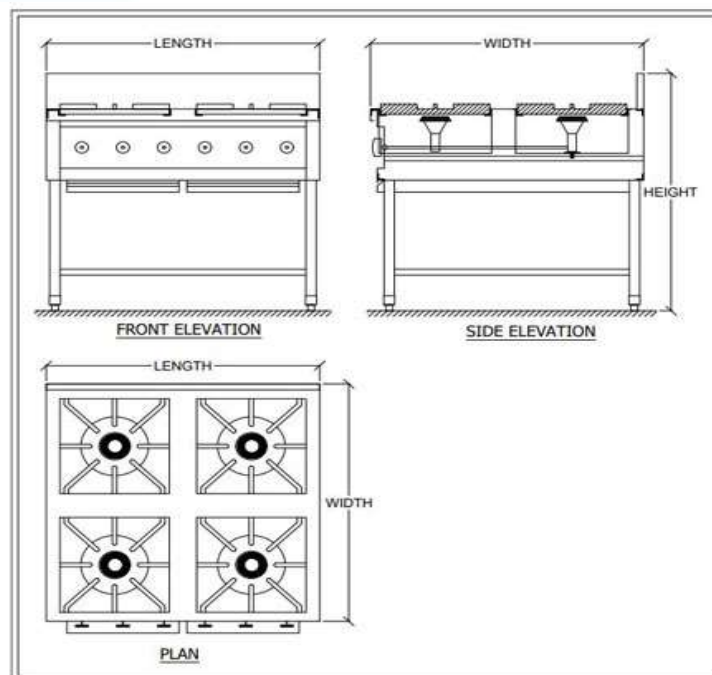

STOCK POT RANGE

It's a very big impact when a 100 Kg loaded vessel is put on the stock pot burner, to withstand the impact STAR OPUS range of stock pot burners are made with a very sturdy angular structure, High pressure burners for faster cooking and big sturdy pan rest to accommodate the vessel.



Stock Pot Range

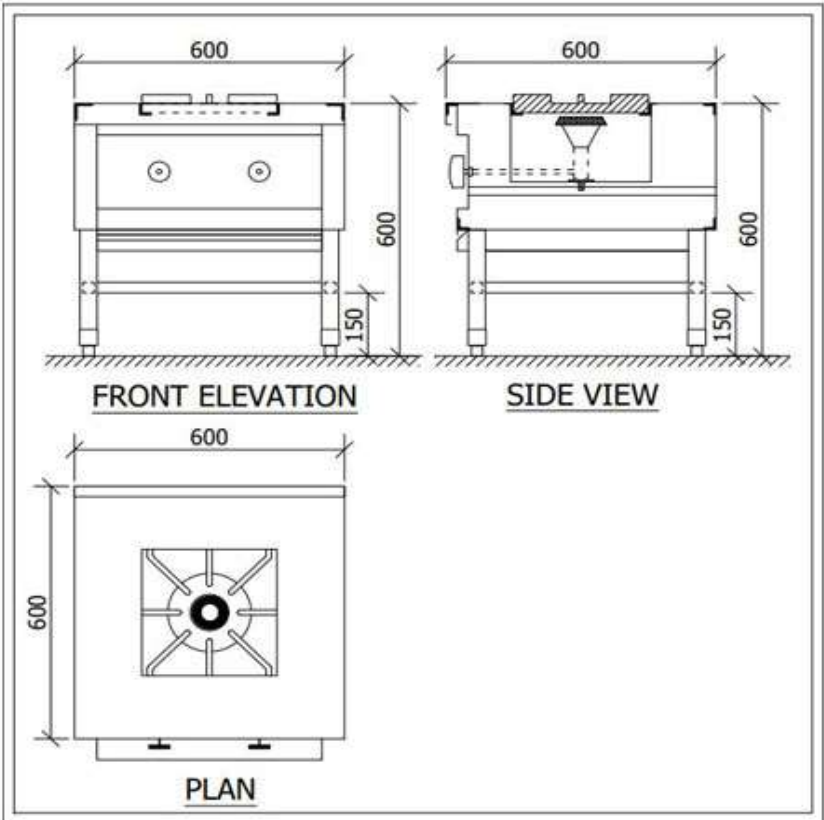

PRODUCT FEATURES

- Single Burner Indian Range available in 600/750 & 900 mm depth
- 304 in Standard model & 202 in Economical model, 1.2mm thick Stainless Steel Top
- Cast Iron durable Pan rest
- Quality tested Burners
- Pilot Lamp for Each Burner
- Bigger durable knobs for ease of operation, colour coded knobs, Red for Main Burner & Black for Pilot Lamps
- Angular Frame structure constructed out of 25mm x 25mm x 3mm thick Stainless Steel Angles
- Cladding with units constructed out of 1mm thick Stainless Steel Sheet
- Full length Drip Tray for collecting crumbs of food & spillage constructed out of 1mm Stainless Steel Sheet
- Legs constructed out of 38mm square/round Stainless Steel Pipes
- Cross Bracing constructed out of 25mm square/round Stainless Steel Pipes
- Shelves constructed out of 1mm thick Stainless Steel sheet
- Legs resting on adjustable Nylon Bullet to accommodate uneven flooring
- All TIG welded for exposed areas & polished to No.4 Finish

OPTIONAL ACCESORIES

- Back /One /Two side Cladding above shelf constructed out of 1mm thick Stainless Steel Sheet.
- Strong & Durable Castor Wheels.
- Ask us for Customization of your Requirement.



info@opusinnovations.in



Mumbai - (+91) 8452840506 Goa - (+91) 9860555648
Kolkata - (+91) 9830300238 Raipur - (+91) 9425208979



Unit Q1, Khan Compound, Vasai Highway,
Pelhar, Vasai, Palghar, Mumbai (M.H.) - 401202